

relax and allow us
to take control

Vibration Isolator P 51

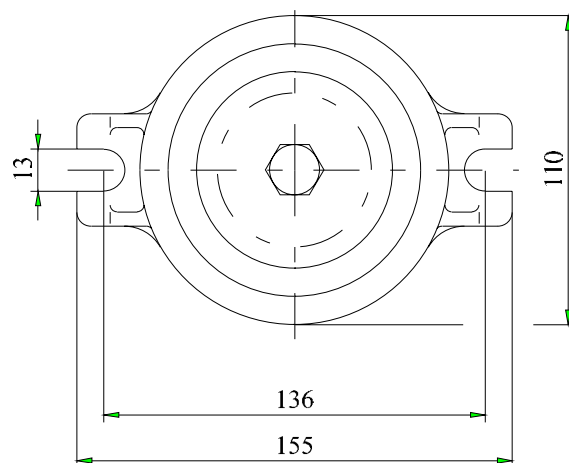
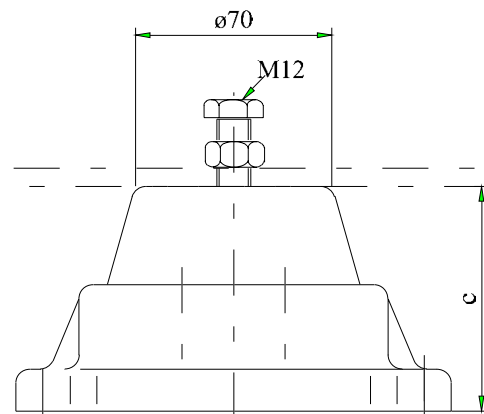

Application:
Vibration isolation of machines and installations

Technical data:
Load up to 1,25kN.

Design:
Compact steel cast housing, helical spring following
DIN 2098.

type	vertical			height c [mm]		weight [kg]
	allowed load F [kN]	C vert [kN/cm]	natural frequency [Hz]	at delivery	under load	
P51 / 122	0,07 - 0,11	0,03	3,31 - 2,57	98	72 - 57	0,7
P51 / 124	0,26 - 0,43	0,10	3,13 - 2,43	98	87 - 70	0,7
P51 / 126	0,47 - 0,79	0,19	3,17 - 2,46	98	88 - 72	0,7
P51 / 117	0,75 - 1,25	0,37	3,52 - 2,72	98	88 - 74	0,7